

NST | MANUAL TILTING ROTARY TABLE

- Table can be tilted at 0°~90° manually
- Indexing is CNC controlled so that it can be adapted to all kinds of machining
- Suitable for wide variety of applications thanks to numerical tilting axis control

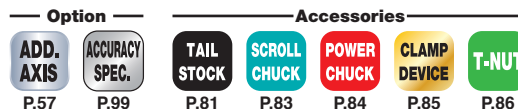
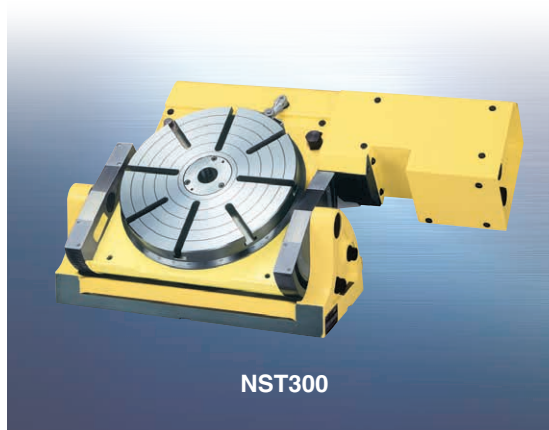

■ Specifications

Item / Code No.		NST250	NST300	NST500
Diameter of Table	φmm	250	300	500
Diameter of Spindle Hole	φmm	φ60H7 φ52	φ60H7 φ60	φ75H7 φ61.5
Center Height	mm	155	208	288
Width of T Slot	mm	12 ^{+0.018} ₀	12 ^{+0.018} ₀	14 ^{+0.018} ₀
Clamping System		Pneumatic*2	Pneumatic*2	Pneumatic*2
Clamping Torque	N·m	147	196	196
Table Inertia at Motor Shaft	($\frac{GD^2}{4}$) kg·m ² ×10 ⁻³	0.39	0.59	0.69
Servo Motor	r/min	α iF2·2000	α iF4·2000	α iF8·2000
MIN. Increment		0.001°	0.001°	0.001°
Rotation Speed	r/min	16.6	11.1	5.5
Total Reduction Ratio		1/120	1/180	1/360
Indexing Accuracy	sec	20	20	20
Net Weight	kg	75	135	320
MAX. Work Load on the Table	90° kg	50	100	200
	Horizontal kg	100	300	500
MAX. Thrust Load applicable on the Table	N	17500	31860	75000
	*1 FXL N·m	603	903	2884
	FXL N·m	770	2010	8330
MAX. Work Inertia	90° + ($\frac{GD^2}{4}$) kg·m ²	1.35	3.37	14.70
Driving Torque	N·m	144	288	1152

*1 This is the strength of the worm wheel without brake. It is applied against dynamic cutting thrust.

*2 Air Intensifying Booster system is available if the supplied air pressure is under 0.5MPa or the brake torque is required to increase. P.95

★ αiF4 motor can be mounted on NST250.

★ αiF8/3000 motor can be mounted on NST300.