

5AX-130, 5AX-201



External dimensions depend on the type of the servo motor. Indicated dimensions are in case of FANUC. Please contact us for CAD files (2D:DXF, 3D:PARASOLID).

5AX-130

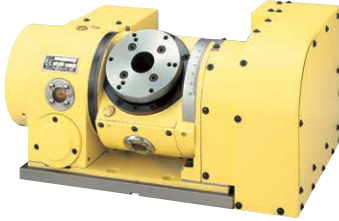
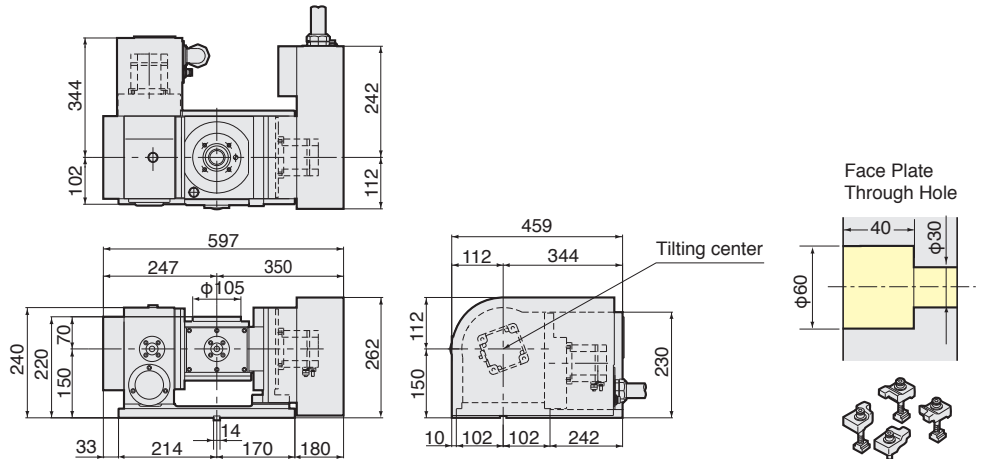

Photo with $\phi 130$ mm plate.
(Standard accessories)



Center height of high column table is 65mm higher than that of standard table.



Clamp Device

5AX-201

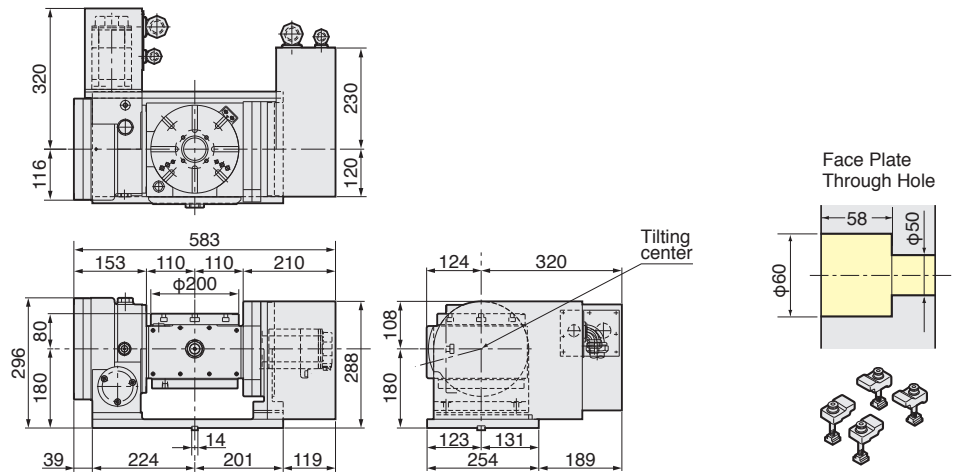
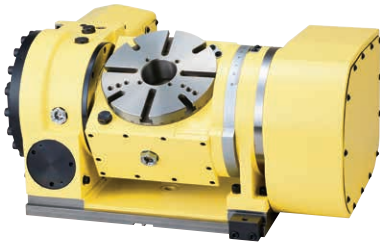

Built-in type 4 ports rotary joint can be attached on standard type as an option. (High column type is not necessary.)



Clamp Device

The Area of Noninterference in Tilting Position.

Angle	5AX-130	5AX-201
0°		
45°		
90°		
105°		

5AX-130BA

The tilting axis motor is mounted at back side.

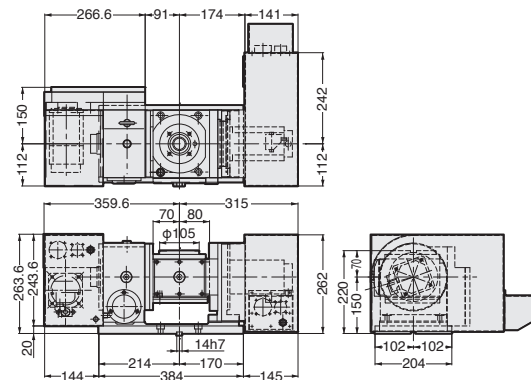

5AX-201BA

The tilting axis motor is mounted at back side.

