

NC5 BALANCE-CUT BORING ARBOR

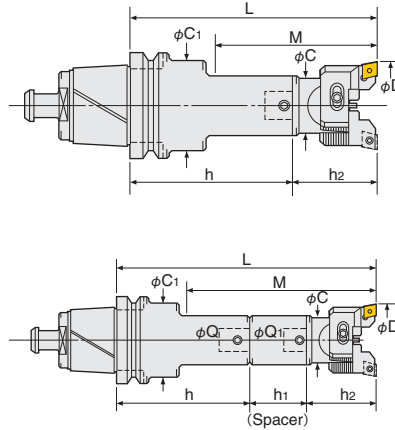

RAC

Photo shows RAC head with A1 spacer.



Power of Shoulder Support

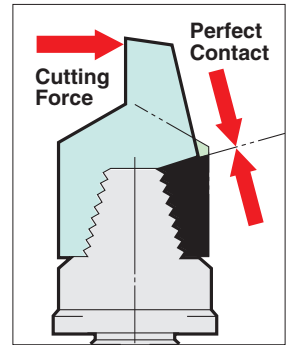

TAPER	Code No.	Boring Range D	Boring Depth M	P.80		Weight (kg)
				Head No.	Insert No.	
NC5-63	NC5- 63-RAC 25-135E, 165E, 180E	25~32	67, 105, 112	12-RAC 25- 55E	CC07-C	1.7, 1.8, 1.8
	-RAC 32-150E, 180E, 195E	32~45	77, 110, 122	16-RAC 32- 55E	CC08-C	2.1, 2.3, 2.3
	-RAC 43-150E, 180E, 210E	43~55	97, 130, 157	20-RAC 43- 70E	CC12-C	2.4, 2.6, 2.9
	-RAC 53-165E, 210E, 225E	53~70	135, 180, 195	26-RAC 53- 70E		2.2, 2.9, 3.0
	-RAC 70-180E, 195E, 240E	70~100	180, 195, 240	34-RAC 70- 85E		4.5, 4.9, 5.9
	-RAC100-195E	100~130	195	42-RAC100-100E		6.5
NC5-85	NC5- 85-RAC 25-150E, 180E, 195E	25~32	67, 105, 112	12-RAC 25- 55E	CC07-C	2.9, 3.0, 3.1
	-RAC 32-180E, 210E, 225E	32~45	77, 110, 122	16-RAC 32- 55E	CC08-C	3.6, 3.8, 3.8
	-RAC 43-180E, 195E, 225E, 240E	43~55	97, 130, 142, 157	20-RAC 43- 70E	CC12-C	3.9, 4.0, 4.3, 4.4
	-RAC 53-210E, 240E, 270E	53~70	117, 182, 177	26-RAC 53- 70E		5.1, 5.2, 5.8
	-RAC 70-255E, 285E, 315E	70~100	205, 235, 265	34-RAC 70- 85E		7.7, 8.1, 9.1
	-RAC100-225E, 290E, 315E	100~130	187, 252, 277	42-RAC100-100E		10.7, 10.7, 14.1
NC5-100	NC5-100-RAC 25-150E, 180E, 195E	25~32	67, 105, 112	12-RAC 25- 55E	CC07-C	3.9, 4.0, 4.1
	-RAC 32-180E, 210E, 225E	32~45	77, 110, 122	16-RAC 32- 55E	CC08-C	4.6, 4.8, 4.8
	-RAC 43-180E, 195E, 225E, 240E	43~55	97, 130, 142, 157	20-RAC 43- 70E	CC12-C	4.9, 5.0, 5.3, 5.4
	-RAC 53-210E, 240E, 270E	53~70	117, 182, 177	26-RAC 53- 70E		6.1, 6.2, 6.8
	-RAC 70-255E, 285E, 315E	70~100	205, 235, 265	34-RAC 70- 85E		8.7, 9.1, 10.1
	-RAC100-225E, 290E, 315E	100~130	225, 290, 315	42-RAC100-100E		11.7, 11.7, 15.1

- ★ "C" grade (Coated) inserts are supplied as standard with the head. P.80 Please refer P.124 for cutting condition.
- ★ Please refer P.252 for base holder, P.108 for spacer and P.85 for head.
- ★ For centre through coolant type, please add "-C" at the end of Code No. e.g. NC5-63-RAC53-165-C
- ★ Cartridges & Insert tips for the Heavy Duty Boring of Iron and Cast Iron (No letter), for Aluminum (A), and for Through Hole & Multiple Sheets (K) are available. Please refer P.85 for cartridges. Please add the letter "No letter", "A" or "K" at the end of Code No. e.g. NC5-63-RAC53-165A
- ★ Cartridge & Insert for Alloy Steel (E) is recommended for boring on steel and stainless steel. e.g. NC5-63-RAC53-165E
- ★ For NC5-46, modular connection system is applied. Please refer P.252 for Base Holder. Code No. of RAC25 and RAC32 with CC inserts are changed to RAC25E and RAC32E. Please refer P.77, P.78
- ★ When L length is required longer than standard, please specify the boring depth M.



High Pressure Coolant Through

