

# 3LOCK BALANCE-CUT BORING ARBOR

**NIKKEN**

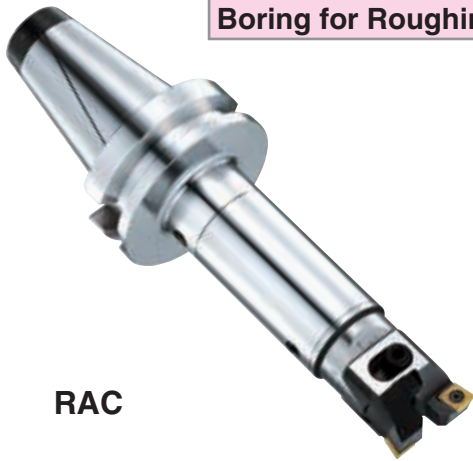

Boring for Roughing

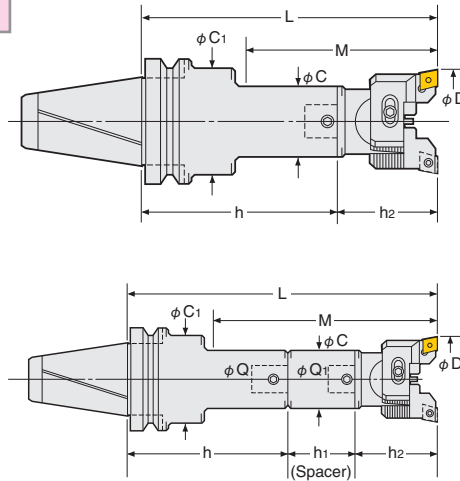

Power of Shoulder Support

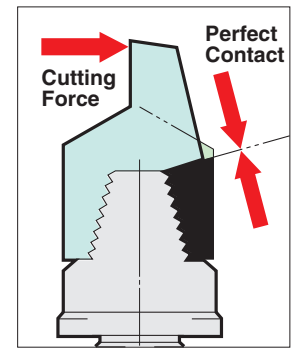

RAC

TAPER	Code No.	Boring Range D	Boring Depth M	Coupling Dia Q	C	C1	P.80		Weight (kg)
							Head No.	Insert No.	
	MBTNo.- Min.D -L						Q- Min.D -h2		
No.40	MBT40-RAC 25-135E, 165E, 180E	25~32	67, 105, 112	12	24	35	12-RAC 25- 55E	CC07-C	2.0, 2.1, 2.1
	-RAC 32-150E, 180E, 195E	32~45	77, 110, 122	16	31	42	16-RAC 32- 55E	CC08-C	2.4, 2.6, 2.6
	-RAC 43-150E, 180E, 210E	43~55	97, 130, 157	20	40	50	20-RAC 43- 70E	CC12-C	2.7, 2.9, 3.2
	-RAC 53-165E, 210E, 225E	53~70	135, 180, 195	26	50	50	26-RAC 53- 70E		2.5, 3.3, 3.2
	-RAC 70-180E, 195E, 240E	70~100	180, 195, 240	34	64	64	34-RAC 70- 85E		4.8, 5.2, 6.2
	-RAC100-195E	100~130	195	42	83	62	42-RAC100-100E		6.8
No.50	MBT50-RAC 25-150E, 180E, 195E	25~32	67, 105, 112	12	24	44	12-RAC 25- 55E	CC07-C	4.7, 4.9, 4.8
	-RAC 32-180E, 210E, 225E	32~45	77, 110, 122	16	31	50	16-RAC 32- 55E	CC08-C	5.4, 5.6, 5.6
	-RAC 43-180E, 195E, 225E, 240E	43~55	97, 130, 142, 157	20	40	60	20-RAC 43- 70E	CC12-C	5.7, 5.8, 6.1, 6.2
	-RAC 53-210E, 240E, 270E	53~70	117, 182, 177	26	50	65	26-RAC 53- 70E		6.9, 7.0, 7.6
	-RAC 70-255E, 285E, 315E	70~100	205, 235, 265	34	64	80	34-RAC 70- 85E		9.5, 9.9, 10.9
	-RAC100-225E, 290E, 325E *	100~130	225, 290, 325	42	83	83	42-RAC100-100E		12.5, 12.5, 16.5

- ★ "C" grade (Coated) inserts are supplied as standard with the head. P.80 Please refer P.124 for cutting condition.
- ★ Please refer P.182 for base holder, P.108 for spacer and P.85 for head.
- ★ For centre through coolant type, please add "-C" at the end of Code No. e.g. MBT40-RAC53-165E-C
- ★ Cartridges & Insert tips for the Heavy Duty Boring of Iron and Cast Iron (No letter), for Aluminum (A), and for Through Hole & Multiple Sheets (K) are available. Please refer P.86 for cartridges. Please add the letter "No letter", "A" or "K" at the end of Code No. e.g. MBT40-RAC53-165A
- ★ Cartridge & Insert for Alloy Steel (E) is recommended for boring on steel and stainless steel.
- ★ \* : MBT50-RAC100-375E, 425E and 475E are also available.

Code No. of RAC25 and RAC32 with CC inserts are changed to RAC25E and RAC32E.  
Please refer P.77, P.78

★ When L length is required longer than standard, please specify the boring depth M.

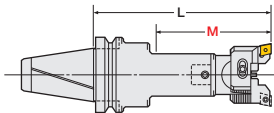

High Pressure Coolant Through Tool