

BALANCE-CUT BORING ARBOR (RAC-E)



Rough Boring — For Steel, Stainless Steel and Cast Iron
CC Insert (Positive type)



RAC-E

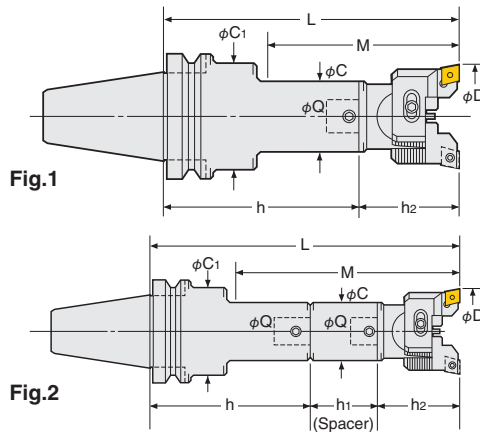

Power of Shoulder Support

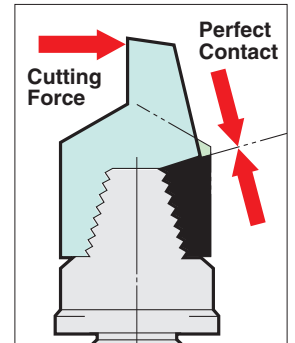

TAPER	Code No.	Boring Range D	Boring Depth M	Coupling Dia Q	C	C ₁	Shank Code No.	Spacer Code No.	P.78		Weight (kg)	Fig
									Head Code No.	Tip No.		
No.40	BT40-RAC 25-135E	25~32	67	12	24	35	BT40-Q12- 80	—	12-RAC 25- 55E	CC07-C	2.0	1
	(IT40) -165E		105				-Q12-110				2.1	
	-180E		112				-Q12- 80				2.1	
	-RAC 32-150E	32~45	77	16	31	42	-Q16- 95	—	16-RAC 32- 55E	CC08-C	2.4	1
	-180E		110				-Q16-125				2.6	
	-195E		122				-Q16- 95				2.6	
	-RAC 43-150E	43~55	97	20	40	50	-Q20- 80	—	20-RAC 43- 70E	—	2.7	1
	-180E		130				-Q20-110				2.9	
	-210E		157				-Q20- 80				3.2	
	-RAC 53-165E	53~70	135	26	50	50	-Q26- 95	—	26-RAC 53- 70E	CC12-C	2.5	1
	-210E		180				-Q26-140				3.3	
	-225E		195				-Q26- 95				3.2	
	-RAC 70-180E	70~100	180	34	64	64	-Q34- 95	—	34-RAC 70- 85E	—	4.8	1
	-195E		195				-Q34-110				5.2	
	-240E		240				-Q34- 95				6.2	
	-RAC100-195E	100~130	195	42	83	62	-Q42- 95	—	42-RAC100-100E	—	6.8	1

★“C” grade (Coated) inserts are supplied as standard with the head. P.78 Please refer P.124 for cutting condition.

★Please refer P.107 for base holder, P.108 for spacer and P.85 for head.

★For centre through coolant type, please add “-C” at the end of Code No. e.g. BT40-RAC53-165-C
Code No. of RAC25 and RAC32 with CC inserts are changed to RAC25E and RAC32E.

★When L length is required longer than standard, please specify the boring depth M.

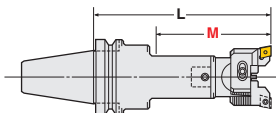

★Code No. of RAC25 and RAC32 are changed to RAC25E and RAC32E.
e.g. BT40-RAC25-135 → BT40-RAC25-135E
12-RAC25- 55 → 12-RAC25- 55E



High Pressure Coolant Through Tool

BALANCE-CUT BORING ARBOR (RAC-E)



Balance cut boring bar executes boring in 2 cartridge inserts absorbing the vibration each other. The faster the feed rate, the better swarf ejection. This is ideal for rough and medium boring.

Double Cutting Capability

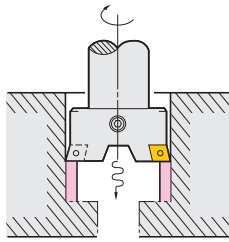

Please use RAC-K for through hole boring.

☞ P.83, P.84



Example of 2 Stepped Balance Cut

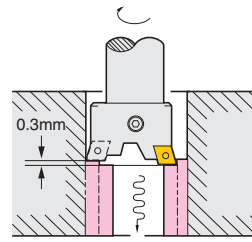

Approx. double removal of below cutting condition is possible by -0.3 Cartridge. ☞ P.86

TAPER	Code No.	Boring Range D	Boring Depth M	Cupling Dia Q	C	C ₁	Shank Code No.	Spacer Code No.	P.78		Weight (kg)	Fig
									Head Code No.	Tip No.		
No.50	BT50-RAC025-150E	25~ 32	67	12	24	44	BT50-Q12- 95	—	12-RAC 25- 55E	CC07-C	4.7	1
	(IT50) -180E		105				4.9					
	-195E		112				4.8					
	-RAC032-180E	32~ 45	77	16	31	50	-Q16-125N	—	16-RAC 32- 55E	CC08-C	5.4	1
	-210E		110				5.6					
	-225E		122				5.6					
	-RAC043-180E	43~ 55	97	20	40	60	-Q20-110	—	20-RAC 43- 70E	CC12-C	5.7	1
	-195E		130				5.8					
	-225E		142				6.1					
	-240E		157				6.2					
	-RAC053-210E	53~ 70	117	26	50	65	-Q26-140	—	26-RAC 53- 70E	CC12-C	6.9	1
	-240E		182				7.0					
	-270E		177				7.6					
	-RAC070-255E	70~100	205	34	64	80	-Q34-170	—	34-RAC 70- 85E	CC12-C	9.5	1
	-285E		235				9.9					
	-315E		265				10.9					
	-RAC100-225E	100~130	225	42	83	83	-Q42-125	—	42-RAC100-100E	CC12-C	12.5	1
	-290E		290				15.2					
	-325E		325				16.5					

★“C” grade (Coated) inserts are supplied as standard with the head. ☞ P.78 Please refer ☞ P.124 for cutting condition. ★Code No. of RAC25 and RAC32 with CC inserts are changed to RAC25E and RAC32E.
 ★Please refer ☞ P.107 for base holder, ☞ P.108 for spacer and ☞ P.85 for head. e.g. BT50-RAC25-150 → BT50-RAC25-150E
 ★For centre through coolant type, please add “-C” at the end of Code No. e.g. BT50-RAC53-210E-C
 ★BT50-RAC100-375E, 425E and 475E are also available. 12-RAC25- 55 → 12-RAC25- 55E

Insert tip for RAC-E

● : best ○ : good

Material	Steel	Stainless Steel	Cast Iron	Aluminium	Coated Carbide M	Coated Carbide K	Grade	
							C	
							Material	Nose R
Applicable Arbor				Code No.	Nose R	AC630M	AC410K	
				CC07-○4	0.4	●	●	
				CC07-○8	0.8	●	●	
				CC08-○4	0.4	●	●	
				CC08-○8	0.8	●	●	
				CC12-○4	0.4	●	●	

Please add the grade indication into ○, and add the insert tip material indication at the end of the Code No. e.g. CC12-C8 (AC630M)

★Minimum order quantity : 10pcs.