

NC5 MILLING CHUCK

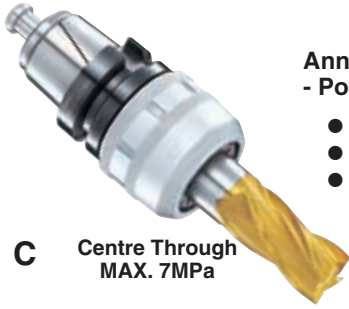

Anniversary Type
- Powerful Gripping Torque -

- High Rigidity
- High Precision
- Compact Design

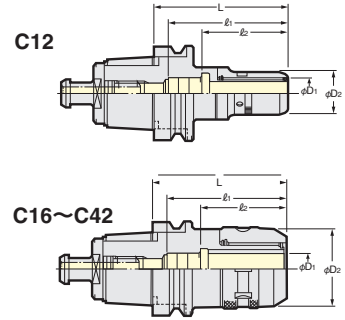

C Centre Through
MAX. 7MPa

TAPER	Code No.	D ₁	D ₂	ℓ ₁	ℓ ₂	L	Collet	Stopper	Weight(kg)	
NC5- 46	NC5- 46-C12- 55	12	33	56	46	58	KM12 CCK12	—	0.6	
	-C16- 70	16	44	63	49	70	KM16 CCK16		—	0.8
	-120			65		120				1.2
	-C20- 80	20	52	72	57	80	KM20 CCK20 CCNK20 NK20	9MC20HS		1.0
	-C25- 90	25	55	80	60	90	KM25 CCK25 CCNK25 NK25	9MC25H	1.3	
	-C32-100*	32	64	75	66	100	KM32 NK32	—	1.6	
NC5- 63	NC5- 63-C12- 65	12	33	56	46	65	KM12 CCK12	—	1.2	
	-C16- 60	16	44	65	49	63	KM16 CCK16		—	1.4
	- 70					70				1.5
	-120					120				2.0
	-150					150				2.3
	-C20- 70	20	52	79	57	71	KM20 CCK20 CCNK20 NK20	9MC20H		1.6
	- 80					80			1.7	
	-120					120			2.3	
	-150					150			2.6	
	-C25- 70	25	60	80	60	71	KM25 CCK25 CCNK25 NK25		9MC25H	1.9
	- 90					80		2.1		
	-120					120		2.7		
	-150					150		3.0		
	-C32- 80*	32	69	71	65	82	KM32 CCK32 CCNK32 NK32	—		2.1
	- 90			77	67	90		9MC32HS	2.3	
	-120			81	70	120		9MC32H	2.9	
-150	81			70	150	9MC32H		3.2		
NC5- 85	NC5- 85-C12- 80	12	33	56	46	80	KM12 CCK12	—	2.2	
	-C16- 80	16	44	65	49	80	KM16 CCK16		—	2.6
	-120					120				3.0
	-160					160		3.3		
	-C20- 80	20	52	80	57	80	KM20 CCK20 CCNK20 NK20	9MC20HL	2.8	
	-120					120		9MC20H	3.3	
	-160					160		9MC20H	3.6	
	-C25- 80	25	60	80	60	80	KM25 CCK25 CCNK25 NK25	9MC25H	2.9	
	-120					120		9MC25H	3.7	
	-160					160		9MC25H	4.0	
	-C32- 85	32	69	81	70	87	KM32 CCK32 CCNK32 NK32	9MC32HS	3.2	
	-100					100		9MC32H	3.6	
	-160					160		9MC32H	5.3	
	-200					200		9MC32H	5.8	
	-C42-105*	42	86	93	73	105	KM42 CCK42 CCNK42 NK42	—	4.8	
	-125			113		125		9MC42H	5.3	
-160	125			160		9MC42H		6.6		
-200	125			200		9MC42H		7.0		

▶ NEXT PAGE ▶▶▶