

MILLING CHUCK

NIKKEN

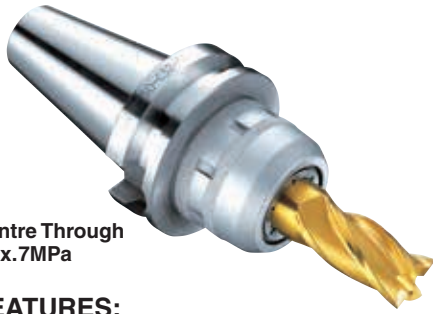

C
Centre Through
Max.7MPa

FEATURES:

- Doubled rigidity & increased cutting ability!
- Run-out Accuracy: 5µm at 3XD

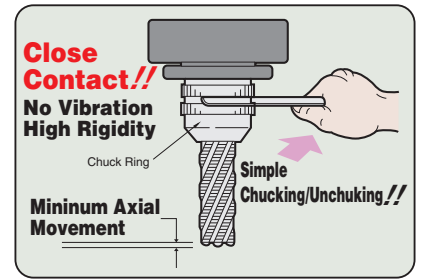
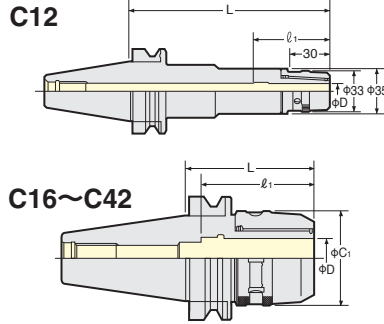

TAPER	Code No.	D	C ₁	L	l ₁	Suitable Collet	Weight(kg)	
No.30	BT30-C12- 55	12	33	58	58	CCK12 KM12	0.6	
	-C16- 55	16	44	57	65	CCK16 KM16	0.7	
	-C20- 65* ¹	20	52	67	80	CCK20 CCNK20 KM20 NK20	1.0	
	- 75			75			1.1	
	-C25- 75* ²	25	55* ⁴	75	68	CCK25 CCNK25 KM25 NK25	1.2	
	- 80			82			1.3	
	-C32- 90* ³	32	64* ⁴	90	68	CCK32 CCNK32 * ⁵ KM32 NK32 * ⁵	1.4	
-100	100			76			1.5	
No.35	BT35-C12- 60	12	33	60	58	CCK12 KM12	1.0	
	-C16- 60	16	44		65	CCK16 KM16	1.1	
	-C20- 70	20	52	70	80	CCK20 CCNK20 KM20 NK20	1.3	
	-C25- 75	25	60	75	68	CCK25 CCNK25 KM25 NK25	1.5	
	-C32- 85	32	64* ⁴	85	77	CCK32 CCNK32 KM32 NK32	1.8	
No.40	BT40-C12- 65	12	33	65	58	CCK12 KM12	1.3	
	- 90			90	65		1.6	
	-120			120	65		1.9	
	-C16- 60	16	44	63	65	CCK16 KM16	1.4	
	- 90			90			65	1.7
	-120			120			65	2.0
	-C20- 70	20	52	71	80	CCK20 CCNK20 KM20 NK20	1.6	
	- 90			90			80	1.8
	-105			105			80	2.0
	-120			120			80	2.2
	-C25- 70	25	60	70	80	CCK25 CCNK25 KM25 NK25	1.8	
	- 90			90			80	2.1
	-120			120			80	2.5
	-C32- 85	32	69	85	77	CCK32 CCNK32 KM32 NK32	2.1	
-105	105			90			2.5	
-120	120			105			2.8	
No.45	BT45-C12-105	12	33	105	58	CCK12 KM12	3.0	
	-C16-105	16	44		65	CCK16 KM16	3.2	
	-C20-105	20	52		80	CCK20 CCNK20 KM20 NK20	3.5	
	-C25-105	25	60			CCK25 CCNK25 KM25 NK25	3.8	
	-C32- 85	32	69		85	105	CCK32 CCNK32 KM32 NK32	3.3
	-C42-110	42	86		110	125	CCK42 CCNK42 KM42 NK42	4.5