

Enables quick jig exchange and work exchange

Out-of-the-box setup significantly increases machine operation rate

Streamlining and labor-saving achieved immediately with a CNC rotary table

MULTI JIG HOLDER SYSTEM

Improve on-site setup with Nikken Multi-Jig Holder System



MJ Holder
(Multi Jig Holder)

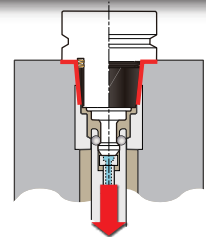

A unique multi-jig holder that achieves high concentricity and strong binding force.

Image of multi-jig holder application configuration

4-axis machining
+
Multi-piece jig

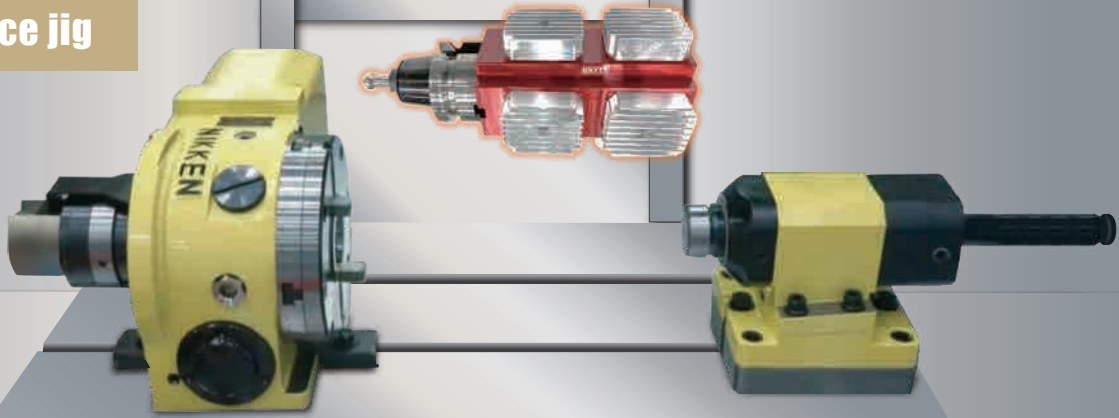

★ The shape of the tailstock center will be a special specification depending on the jig.

Securely holds long multi-piece jig in combination with standard optional tailstock

Additional Axis Specifications

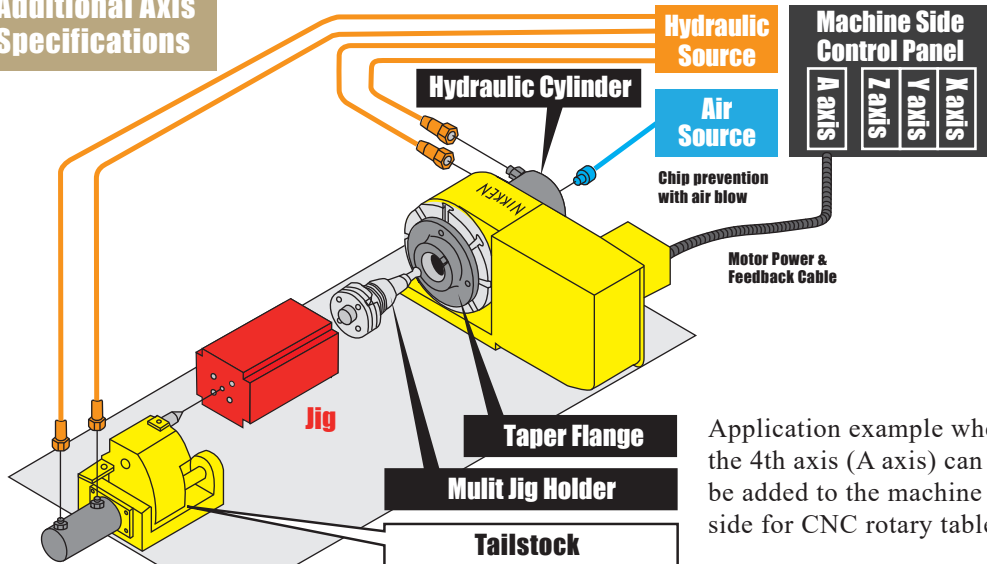

Application example when the 4th axis (A axis) can be added to the machine side for CNC rotary table

Tailstock



Hydraulic type



Small type for both pneumatic & hydraulic

AR21 Controller

Custom options are available with M functionality for control of hydraulic tailstocks and other actuators.



Hydraulic Unit TCC-150

MAX. 1.4 L/min
MAX. 3.5MPa

Power: 3 Phase AC200~220V 1.0kVA



Can support machines that cannot add a 4th axis and can be retrofitted on to existing machines

M Signal Specifications

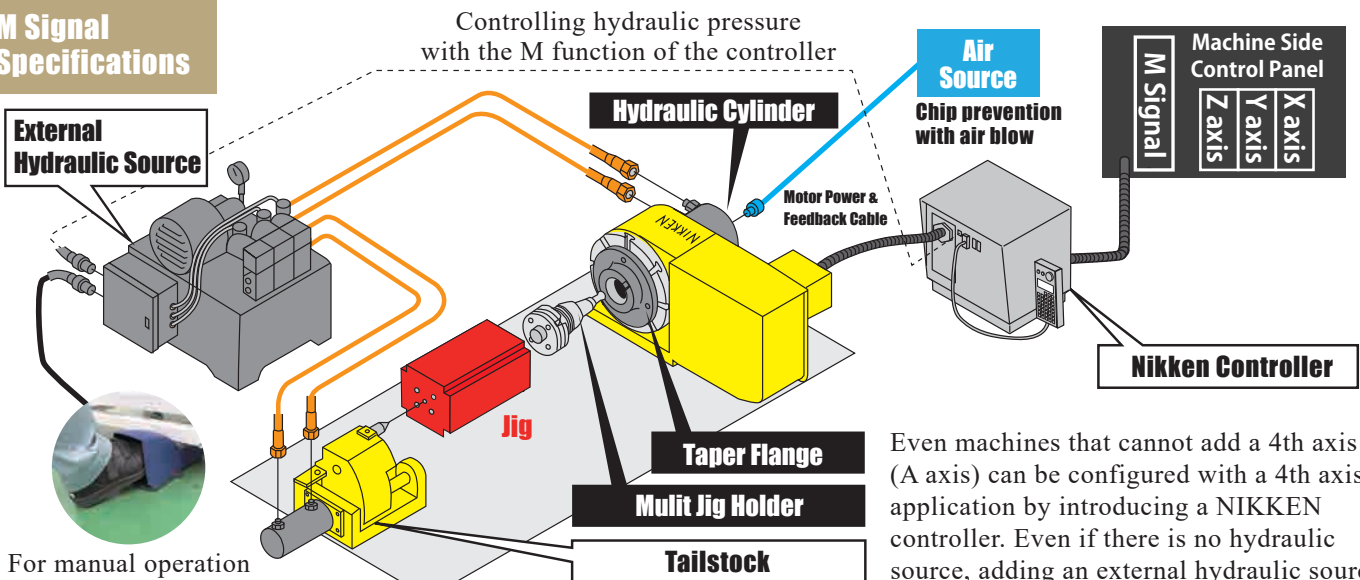

For manual operation using the foot pedal or hand switch

Even machines that cannot add a 4th axis (A axis) can be configured with a 4th axis application by introducing a NIKKEN controller. Even if there is no hydraulic source, adding an external hydraulic source as shown in the figure makes it possible.

★ Please consult with us separately regarding tailstock control methods and specifications.

Compatible with various jig holding methods
3 types of multi-jig holders to choose from

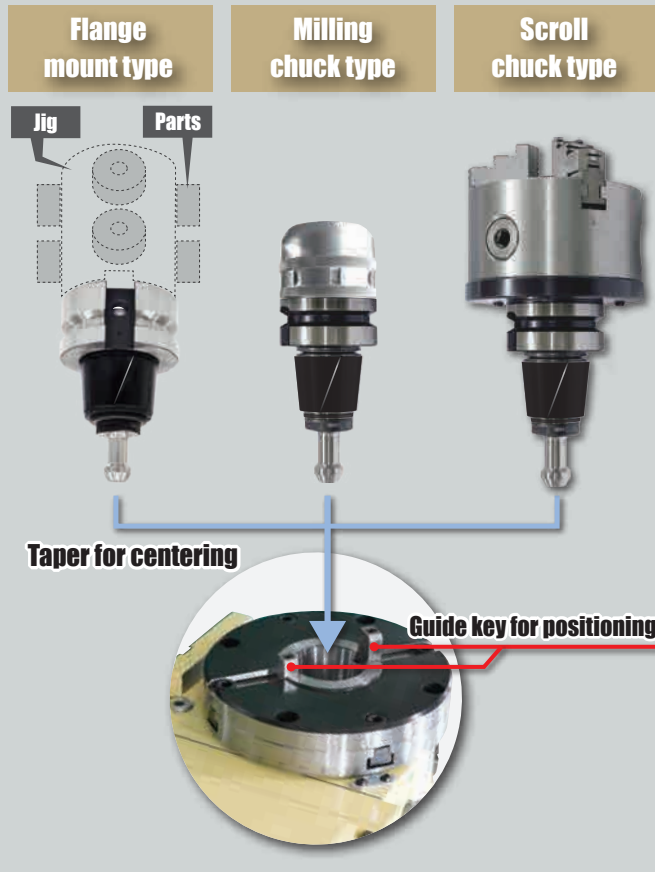

High rigidity & strong clamp
Using proprietary dual contact interface

Unclamping

When unclamping, air is released to clean the taper.

Clamping

Adopts a 12° short taper with gradual angle that achieves high static rigidity. Due to the unique structure that combines the tapered cones, the tapered cones collapse during clamping to improve adhesion.

Dual-face contact

When the holder is clamped down according to the contraction of the tapered cone, the disc spring inside makes contact with the face as it contracts. The taper and the end face are dual-face contact, achieving high rigidity.

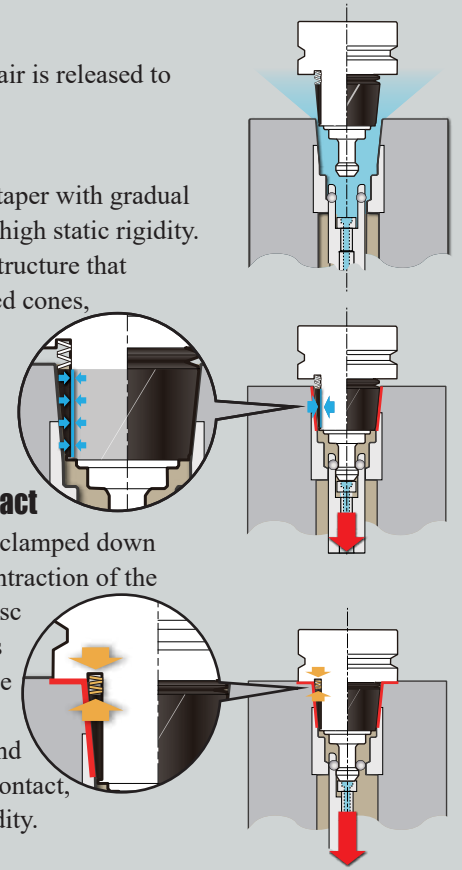

Flange mount type multi jig holder

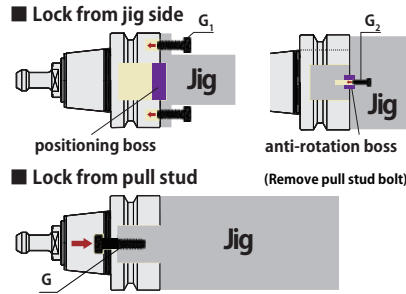
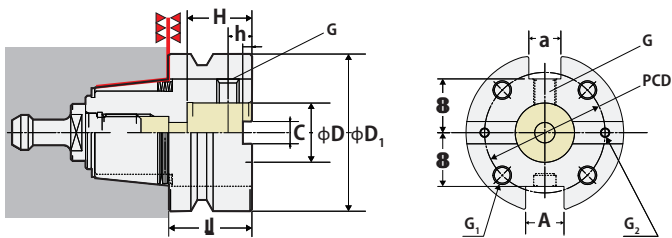

Code No.	Target Model	L	D	D ₁	H	h	A ^{+0.2}	a ^{±0.005}	B	C	PCD	G	G ₁	G ₂	Mounting weight	Weight
RN40-63-25-PS332	CNC105	40	25H ₆	63	30	15	18	16	22.5	10H ₇	48	M10×25L	M 8×15L	M4× 8L	Approx. 8kg	1.5kg
	5AX-130															
	CNC180															
RN45-85-32-PS3	CNC202	45	32H ₆	85	35	20	20	18	29	12H ₇	65	M10×25L	M10×15L	M5×10L	Approx. 10kg	2.5kg
	CNC260P															
	5AX-201															

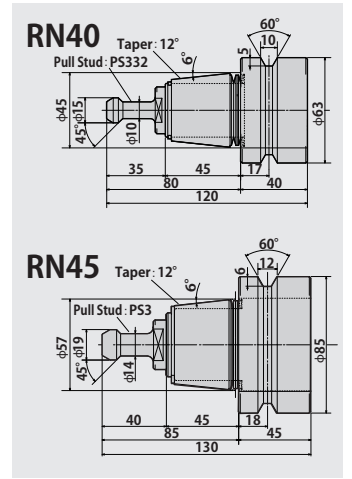

Milling chuck type multi jig holder

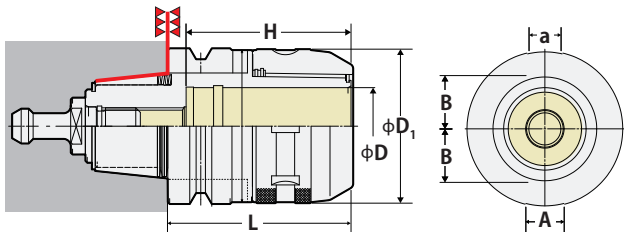

Code No.	Target Model	L	D	D ₁	H	A ^{+0.2}	a ^{±0.005}	B	Weight
RN40-C32-90-PS332	CNC105	90	32	69	77	18	16	22.5	2.5kg
	5AX-130								
RN45-C32-100-PS3	CNC180	100	32	69	85	20	18	29	3.8kg
	CNC202								
	CNC260P								
RN45-C42-100-PS3	5AX-201	100	42	84	90	20	18	29	4.5kg
	CNC180								
	CNC202								
	CNC260P								
5AX-201									

Scroll chuck type multi jig holder

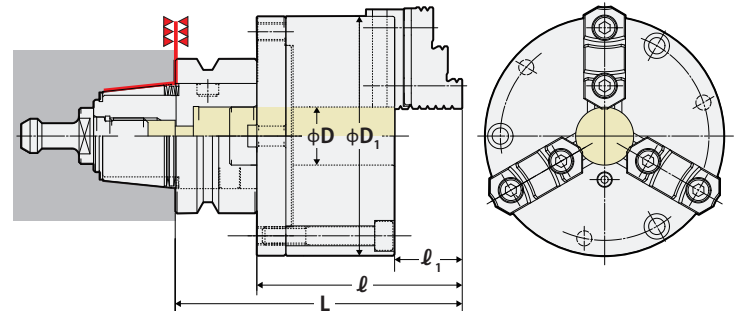

Code No.	Target Model	L	l	l ₁	D	D ₁	Chuck Size	Grip Range* OD ID	Weight
RN40-SC4-PS332	CNC105	141.3	101.3	31.25	24	112	4"	2~ 89 36~78	6kg
	5AX-130								
	CNC180								
RN45-SC5-PS3	CNC202	158.3	113.3	37.25	32	132	5"	3~104 42~92	9.5kg
	CNC260P								
	5AX-201								
	5AX-201								

*A range that can be gripped reliably. Not the jaw stroke.

STEP 1 Easy and immediate labor saving with multi-jig holders

- ◆ Set-up outside the machine during machining process
- ◆ Mounting a workpiece on a multi-piece jig

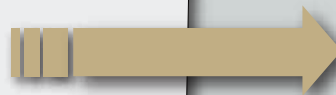
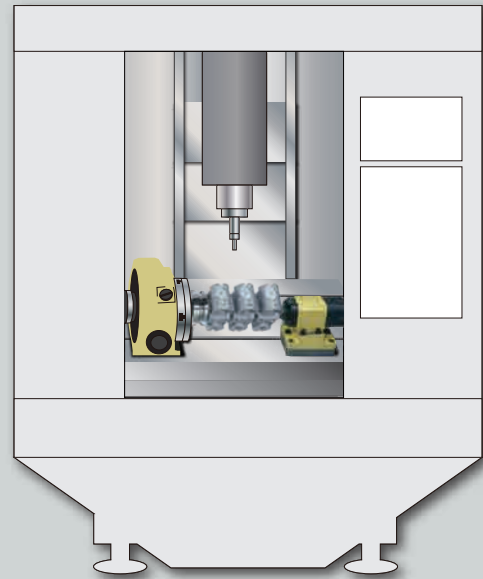
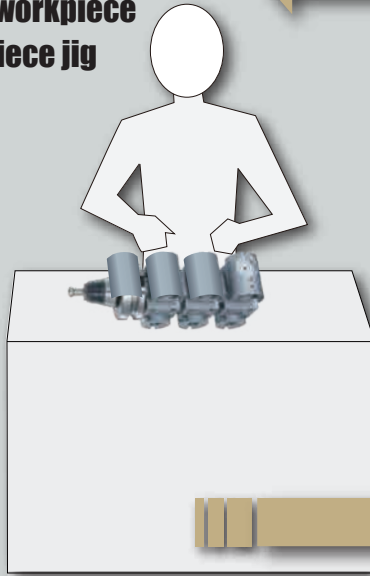

- ◆ Non-stop machining of multiple workpieces
- ◆ Enables long-term unmanned continuous operation

EASY ①

If you use a multi-jig holder that exhibits high concentricity, you don't need skill or experience for centering work.

EASY ②

By using a multi jig that attaches multiple workpieces to a single jig, you can easily achieve high-efficiency continuous machining with external setup.

EASY ③

By exchanging the jigs on the multi-jig holder, different workpieces can be handled, enabling high-mix low-volume production.

Standard System Configuration

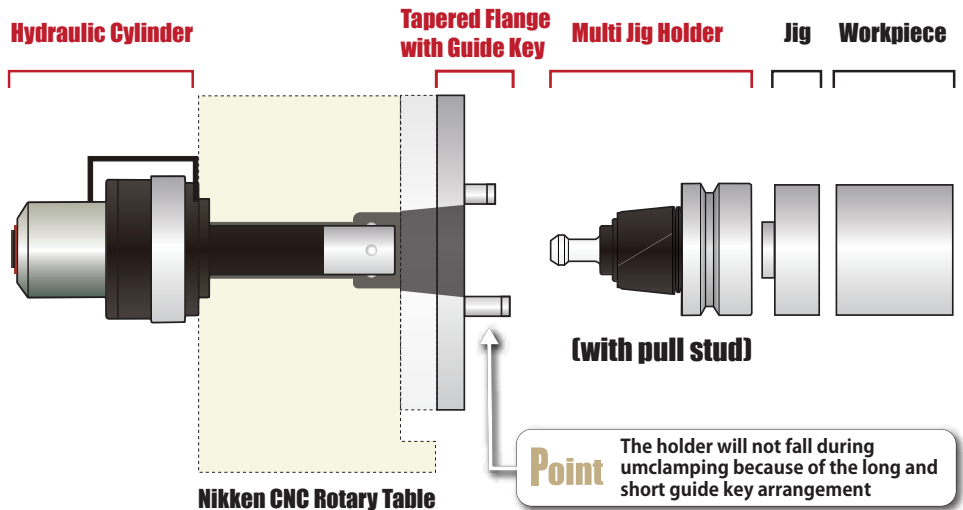

Target CNC Rotary Table				Flange mount type multi jig holder	Draw Bolt (3.5MPa/Draw force 7.9KN)	Tapered flange with guide key	Tailstock* ³ (standard option)
Spec	Face Plate Dia.	Additional axis specification ^{*2}	M signal specification				
1 axis	φ100	CNC105(L)FA	CNC105(L)AR21-04	RN40-63-25-PS332	HYD-PD-CN105	TF40-GKYE-CN105	PBA-105 (Air/Hydraulic) * ⁴
	φ180	CNC180(L)FA	CNC180(L)AR21-04	RN45-85-32-PS3	HYD-PD-CN180	TF45-GKYE-CN180	PBA-135 (Air/Hydraulic) * ⁴
	φ200	CNC202(L)FA	CNC202(L)AR21-08	RN45-85-32-PS3	HYD-PD-CN180	TF45-GKYE-CN180	PBA-135 (Air/Hydraulic) * ⁴
	φ260	CNC260P(L)FA	CNC260P(L)AR21-08	RN45-85-32-PS3	HYD-PD-CN26P	TF45-GKYE-CN26P	PBA-170 (Air/Hydraulic) * ⁴ H-170S (Hydraulic)
2 axes ^{*1}	φ130	5AX-130HFA	5AX-130HAR21-0404	RN40-63-25-PS332	HYD-PD-AX130	TF40-GKYE-AX130	-
	φ200	5AX-201HFA	5AX-201HAR21-0408	RN45-85-32-PS3	HYD-PD-AX201	TF45-GKYE-AX201	-

*1: Select the high column specification for the 2-axis models 5AX-130 and 5AX-201.

*2: Code numbers for additional axis specifications are for FANUC motors. For non-FANUC motors, please consult us separately as the code No. will be different.

*3: Specifications for all tailstock strokes are 100mm. The maximum workpiece diameter of H-170S is limited to φ130.

*4: For the PBA series, select either pneumatic or hydraulic depending on the weight and dimensions of the jig and workpiece. Please contact us for specifications such as the tailstock control method.

STEP 2 Automated replacement of multi-jig holders with robots

Off-line setup for efficiency

only one type of robot arm

Non-stop machining with multiple processes using 5-axis multi-face machining

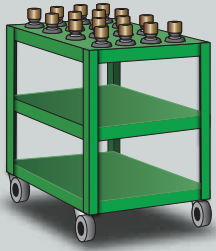

Work (Jig) Stocker

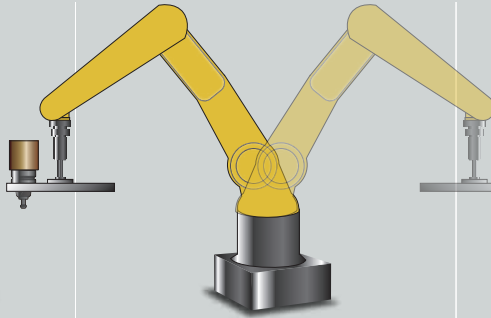

Robot

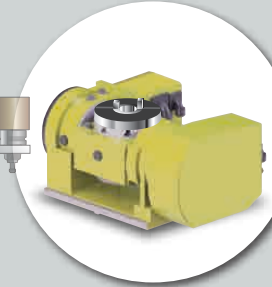

5AX Rotary Table

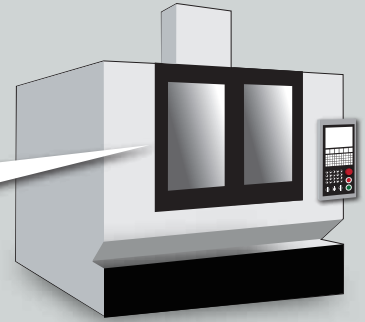

Machining Center

Unmanned operation for hours with using robots

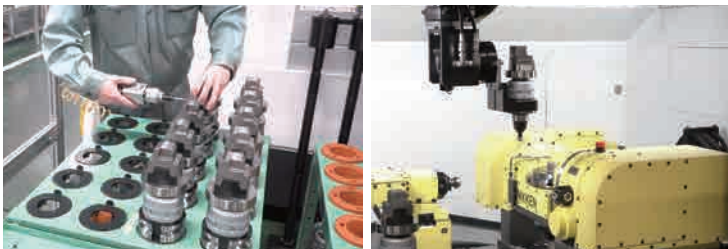

By automating the exchange of multi-jig holders through the use of robots, it is possible to produce off-the-shelf workpieces unattended, even at night and on holidays.

Process integration with using 5AX rotary table



If it is combined with a 5AX rotary table, it is possible to consolidate the process instead of performing setup changes for each machining surface and enable even longer unmanned operation with one chucking.

Point 1 Significantly reduce costs with 1 end-of-arm tooling

Without Multi Jig Holder

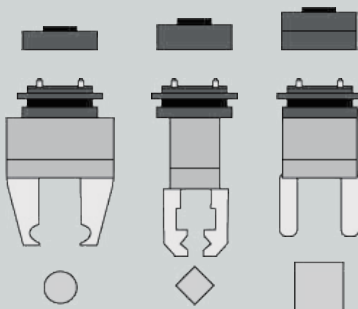
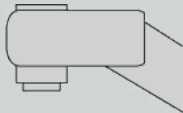

Various end-of-arm tooling to conform to the jig or interface

With Multi Jig Holder

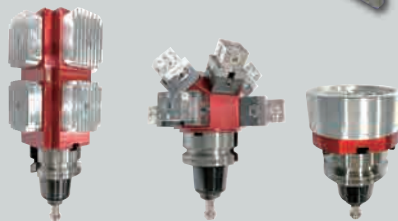
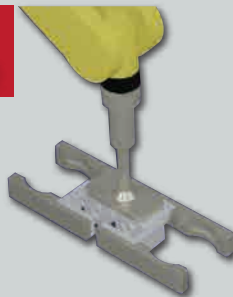

Only one type of end-of-arm tooling required to interface the flange

When automating robot applications, various arms and interfaces are required to match the jigs. In addition, the stocker design and teaching of robot also require additional time and cost. With Nikken's multi-jig holder system, only one type of robot arm that grips the V-flange of the holder is necessary. This will greatly reduce the difficulty of introducing robots in the future.

Point 2 Utilize the tool wagon



Because of its design, it is possible to use a tooling wagon as a stocker. Not only does it make stocker production easier, but it also makes it easier to move and make arrangements for the next process smoothly.

Usage tips

Tips for using a tooling wagon as a stocker

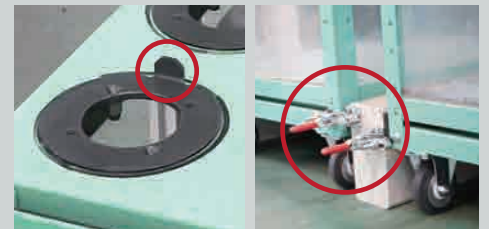

Holder positioning

Wagon positioning

ENTRY STEP Try the manual retraction type first

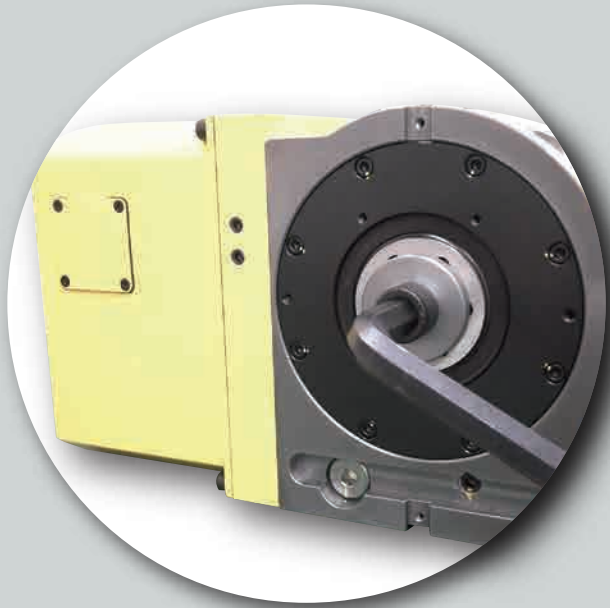

EASY ①

If you use a workpiece mounting jig holder that exhibits high concentricity, no skill or experience is required for centering work.

EASY ②

Streamlining even where introduction of hydraulic pressure is difficult. Simple setup change is possible by simply clamping the multi-jig holder with the jig attached.

Standard System Configuration

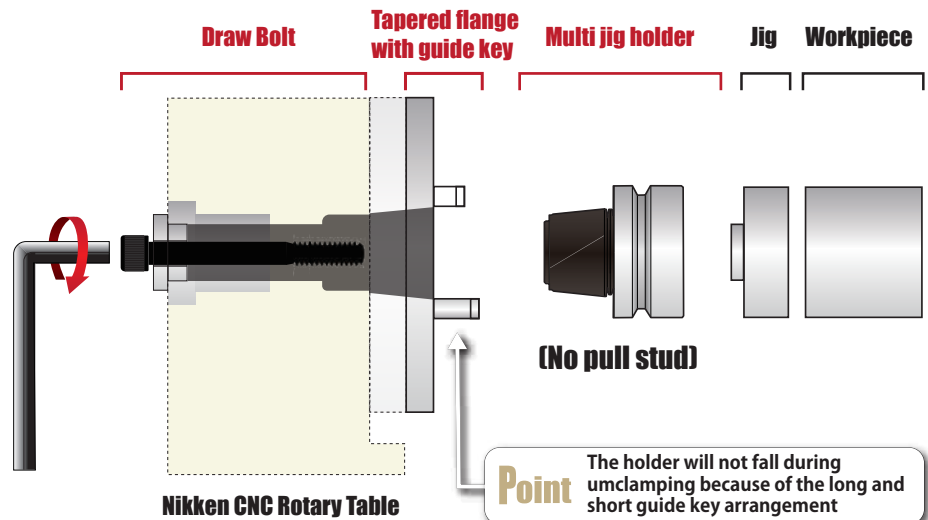

Target CNC Rotary Table				Flange mount type multi jig holder	Draw Bolt (with bolt collar)	Tapered flange with guide key	Notes
Spec	Face Plate Dia.	Additional axis specification	M signal specification				
1 axis	φ100	CNC105(L)FA	CNC105(L)AR21-04	RN40-63-25	PBS-CN105	TF40-GKYE-CN105	
	φ180	CNC180(L)FA	CNC180(L)AR21-04	RN45-85-32	PBS-CN180	TF45-GKYE-CN180	
	φ200	CNC202(L)FA	CNC202(L)AR21-08	RN45-85-32	PBS-CN180	TF45-GKYE-CN180	
	φ260	CNC260P(L)FA	CNC260P(L)AR21-08	RN45-85-32	PBS-CN26P	TF45-GKYE-CN26P	
2 axes	φ130	5AX-130FA	5AX-130AR21-0404	RN40-63-25	PBS-AX130	TF40-GKYE-AX130	
	φ200	5AX-201FA	5AX-201AR21-0408	RN45-85-32	PBS-AX201	TF45-GKYE-AX201	

* Code numbers for additional axis specifications are for FANUC motors. For non-FANUC motors, please consult us separately as the code No. will be different.



NIKKEN KOSAKUSHO WORKS, LTD.
5-1, 1-chome, Minamishinden, Daito-shi, Osaka-fu, Japan

Web: www.nikken-kosakusho.co.jp/en
Tel: +81-(0)72-869-5820 Fax: +81-(0)72-869
e-mail: export@nikken-kosakusho.co