

**NIKKEN**

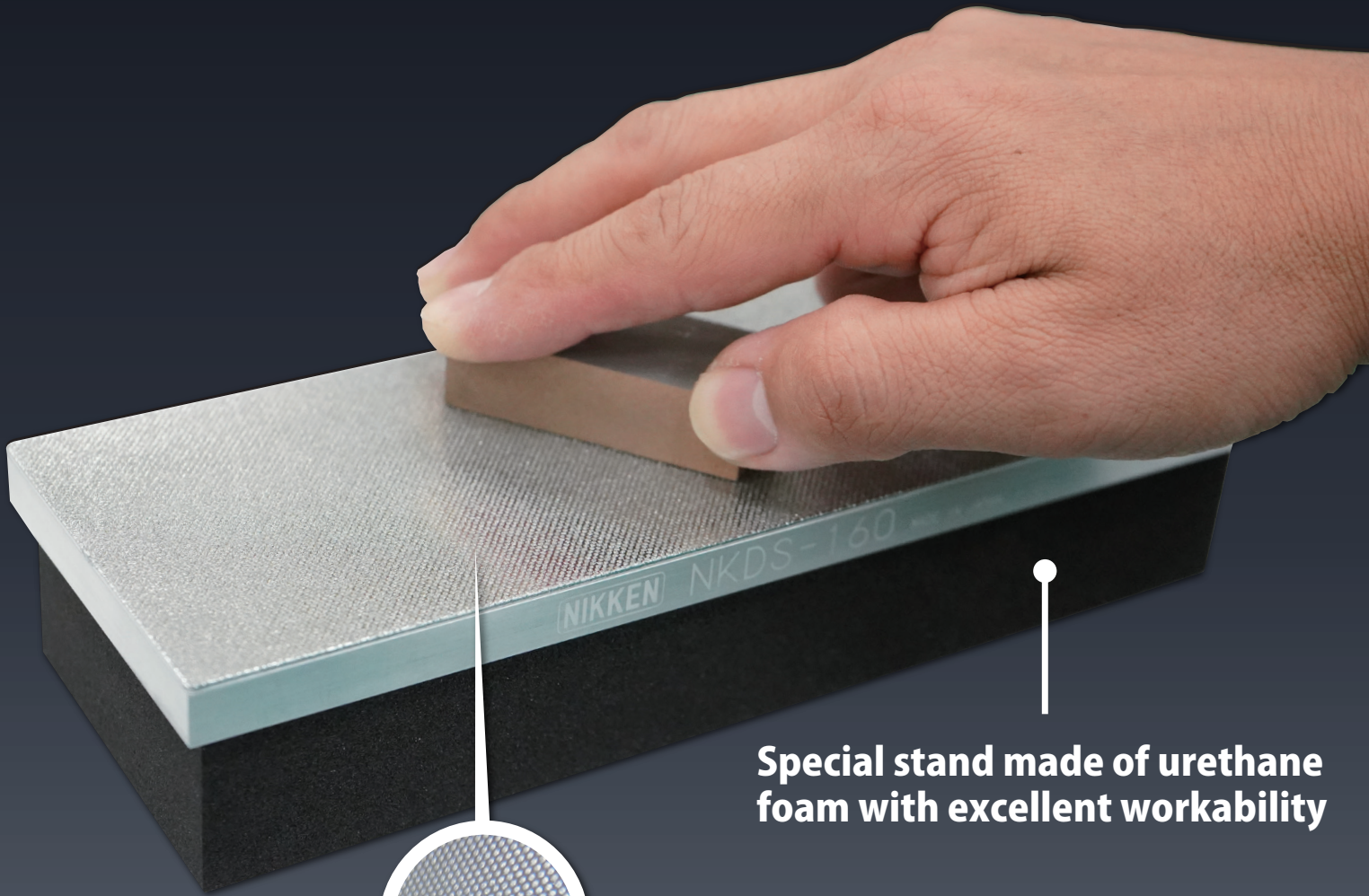

# NIKKEN DIAMOND SURFACE

The Ultimate Tool Enables Quick Surface Restoration of Your Whetstones



Special stand made of urethane foam with excellent workability

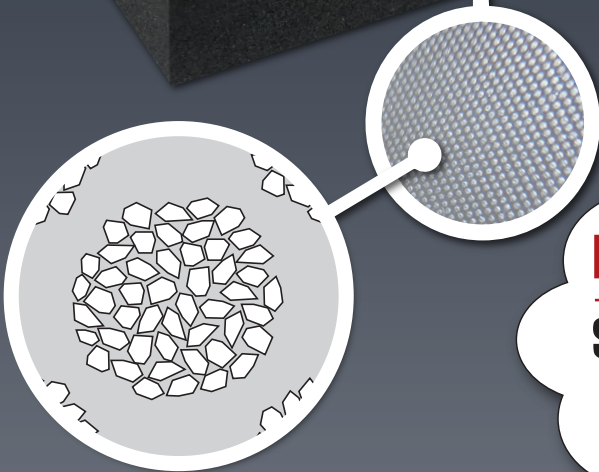

## The Secret of DIAMOND SURFACE

Dots made of diamond abrasive grains are evenly arranged. The aggregation becomes a sharp cutting edge.

## Best of Whetstone Restoration

Surface restoration of the whetstone is completed in **60** seconds.

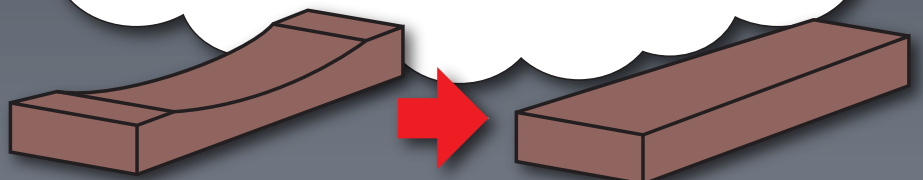

# New NIKKEN DIAMOND SURFACE

**NIKKEN**

All cutting edges of diamonds electrodeposited by a special manufacturing method are aligned, and it provides a smooth feel and uniform polishing.



- ◆ **The use of high quality diamonds provides excellent sharpness and durability.**
- ◆ **Uniformly arranged diamond abrasive grains in a dotted pattern.**
- ◆ **Can be used freely from all directions for workpiece.**
- ◆ **The special stand made of urethane foam with excellent workability.**

## Dimensions

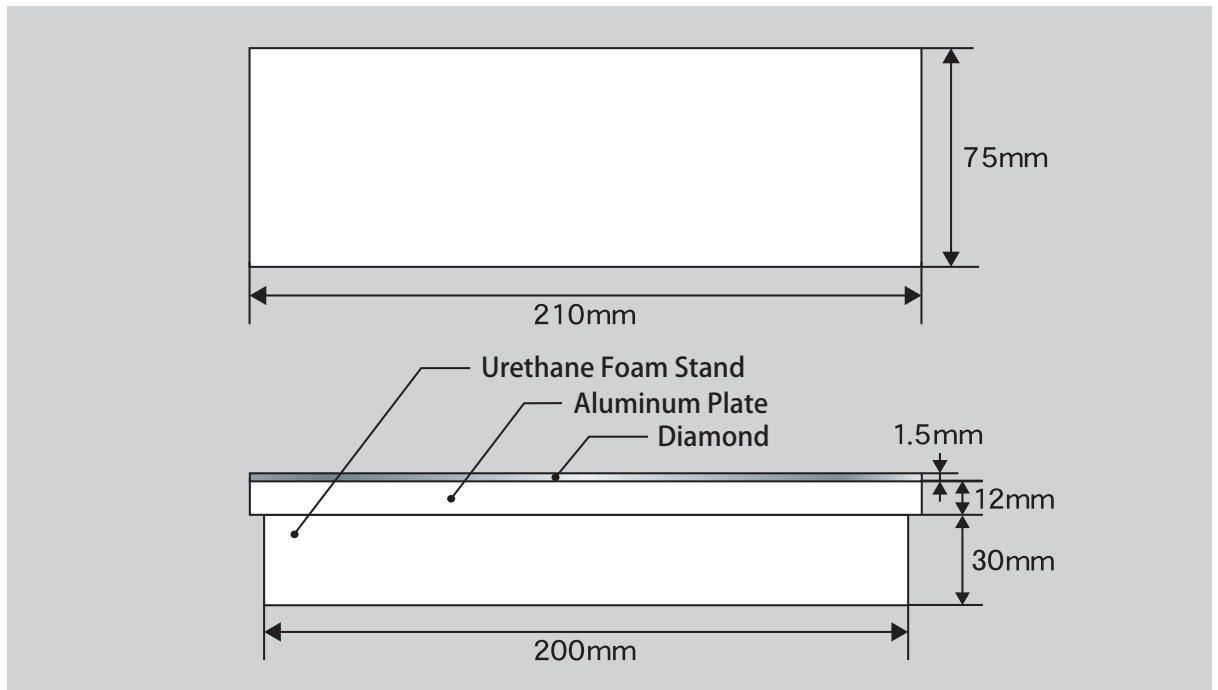

## Specifications

| Grain Size | Surface Roughness | Code No. |
|------------|-------------------|----------|
| #160       | Coarse            | NKDS-160 |
| #400       | Second-cut        | NKDS-400 |
| #600       | Smooth            | NKDS-600 |



**We provides not only high-precision tools but also a fresh new way to maintain tools**

**NIKKEN**

**NIKKEN KOSAKUSHO WORKS, LTD.**